



www.vcx.com.pl

KARTA KATALOGOWA

Ogranicznik przepięć fotowoltaiczny VCX-PV50-B+C klasy T1T2 1000V, 12,5kA GDT



- Dedykowane są do ochrony instalacji fotowoltaicznych.
- Wykonane w technologii warystorowo-iskiernikowej (MOV+GDT+MOV).
- VCX-50PV-B+C klasy T1T2 Iimp (Itotal) = 12,5kA VCX-50PV-B+C klasy T1T2 wyposażony jest w warystory (MOV) w modułach DC+ i DC- oraz iskiernik gazowy (GDT) w module PE co skutecznie eliminuje problem starzenia się iskiernika pod wpływem tzw. prądu upływu i prądu roboczego.
- Wyposażone są w wizualny wskaźnik działania (zielony – ochrona, czerwony – brak ochrony).

Opis techniczny:

Klasa ochrony:	T1 T2
Wykonanie:	warystorowo-iskiernikowe (MOV-GDT-MOV)
Przyłącza max:	35mm ²
Maksymalne napięcie pracy:	Ucpv 1000V DC
Prąd próbny:	In(8/20) 25 kA
Prąd max:	I _{max} (8/20) 50 kA
Prąd impulsowy	I _{imp} (10/350) 12,5kA
Napięciowy poziom ochrony:	Up <4,75
Wytrzymałość zwarciova ISCPV	10kA
Temperatura składowania:	-30/+70°C
Temperatura otoczenia pracy:	-30/+50°C
Klasa szczelności:	IP 20
Czas reakcji	<25ns



www.vcx.com.pl

Pakowanie i oznaczenia:

SERIA	NAZWA WYROBU	OPAKOWANIE	Nr KATALOGOWY
VCX-PV50	Ogranicznik przepięć fotowoltaiczny DC B+C 3P 1000V, 12,5kA GDT	1 sztuka	DC BC3P 1000 PV50 12,5 KA

Schemat podłączenia w modelu VCX- PV50- B+C klasy T1T2 1000V 12,5 kA GDT :

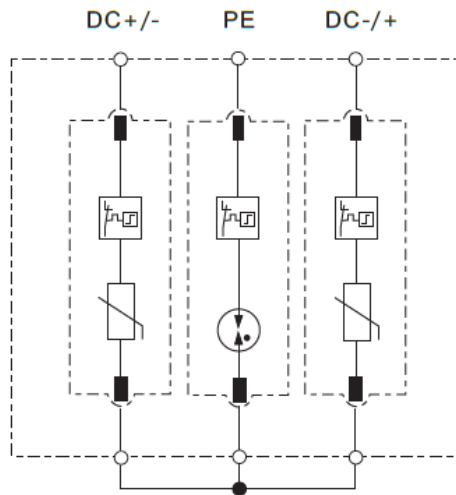

Wymiary:

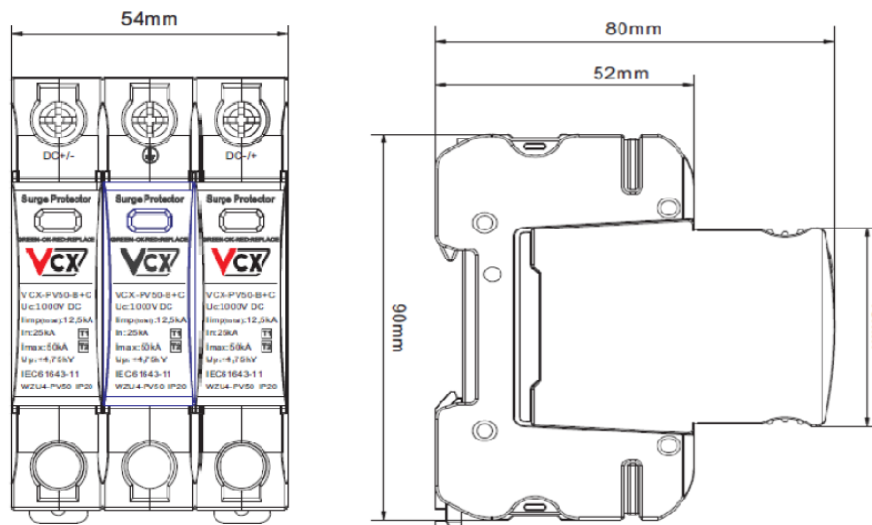



www.vcx.com.pl

DATA SHEET

Surge protector photovoltaic VCX-PV50-B+C class T1T2 1000V, 12.5kA GDT



- They are dedicated to the protection of photovoltaic installations.
- Performed with varistor-isolator technology (MOV+GDT+MOV).
- VCX-50PV-B+C of T1T2 class limp (I_{total}) = 12.5kA VCX-50PV-B+C of T1T2 class is equipped with varistors (MOV) in DC+ and DC- modules and gas spark gap (GDT) in PE module which effectively eliminates the problem of spark gap aging under the influence of so-called leakage current and operating current.
- They are equipped with a visual operational indicator (green - protection, red - no protection).

Technical description:

Klasa ochrony:	T1 T2
Performance:	varistor-isotropic (MOV-GDT-MOV)
Connections max:	35mm ²
Maximum operating voltage:	U _{cpv} 1000V DC
Test current:	I _n (8/20) 25 kA
Max current:	I _{max} (8/20) 50 kA
Impulse current:	I _{limp} (10/350) 12,5kA
Voltage protection level:	U _p <4,75
Short-circuit resistance ISCPV	10kA
Storage temperature:	-30/+70°C
Operating ambient temperature:	-30/+50°C
Leakage class:	IP 20
Response time:	<25ns



www.vcx.com.pl

Packaging and labeling:

SERIES	PRODUCT NAME	PACKAGING	CATALOGUE No.
VCX-PV50	Photovoltaic surge protector DC B+C 3P 1000V, 12,5kA GDT	1 pcs.	DC BC3P 1000 PV50 12,5 KA

Wiring diagram in the model VCX- PV50- B+C class T1T2 1000V 12,5 kA GDT :

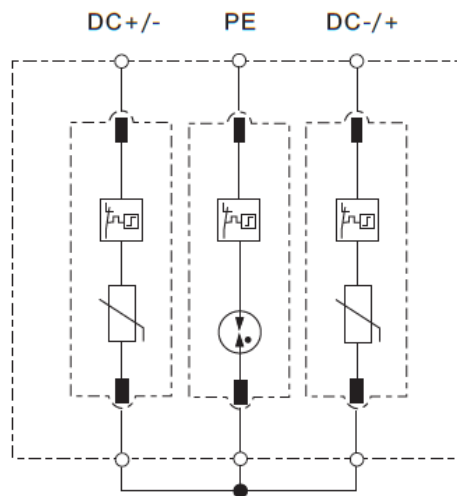

Dimensions:

